

Technische Daten

Lasttabellen

Mit Ballast

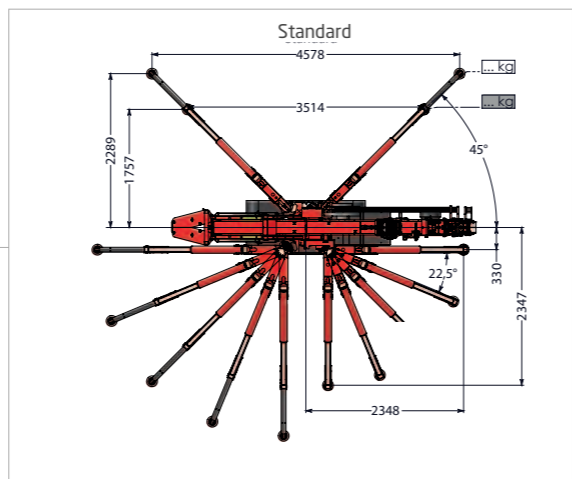
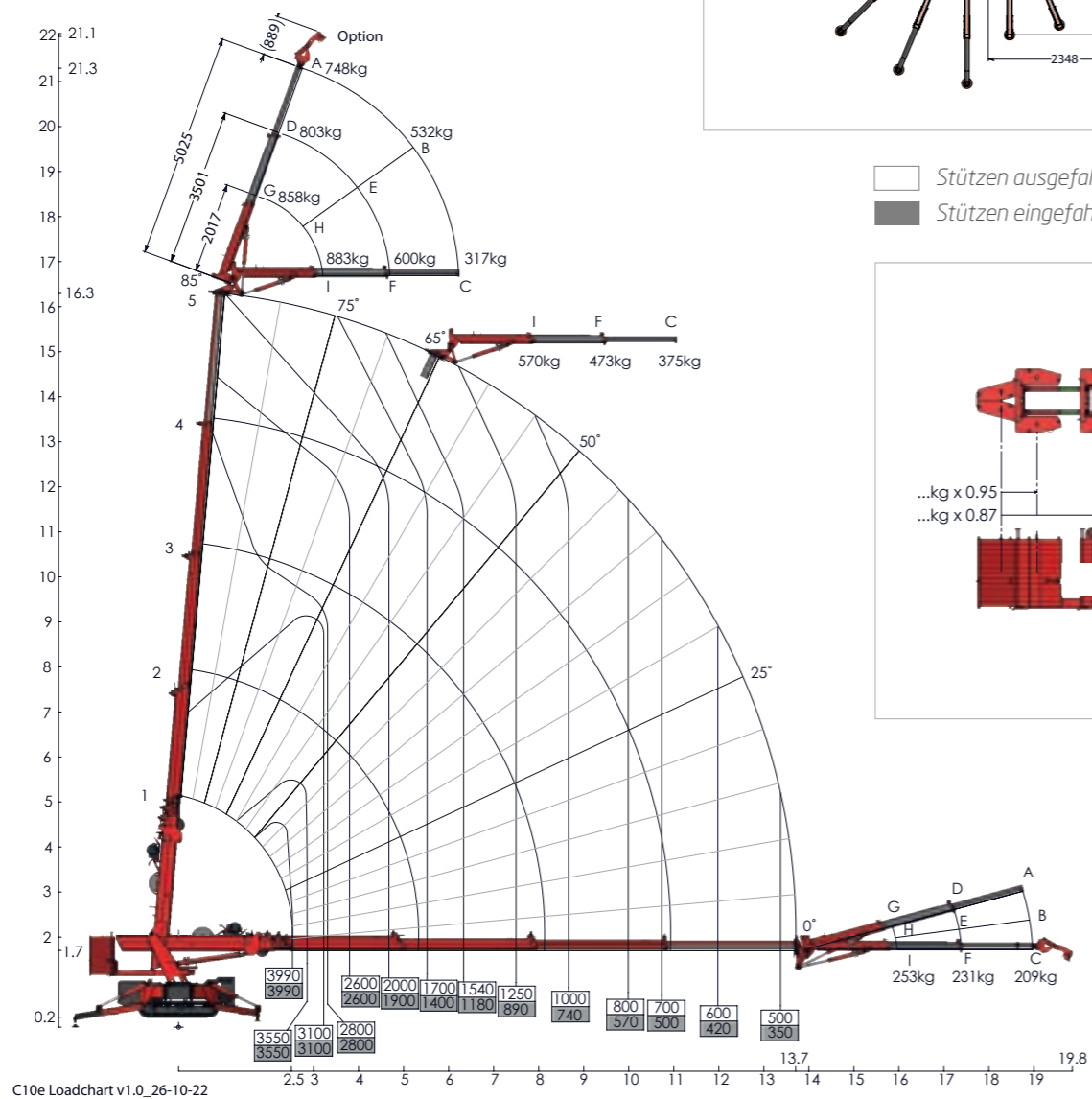

□ Stützen ausgefahren
■ Stützen eingefahren

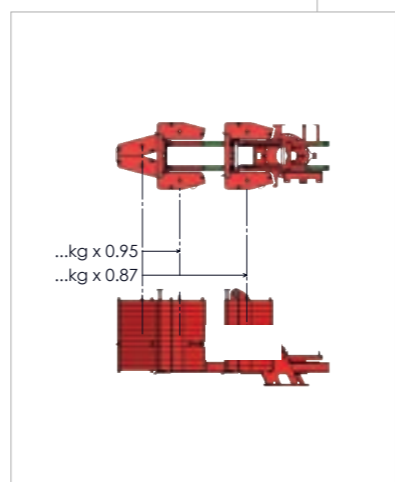

Ohne Ballast

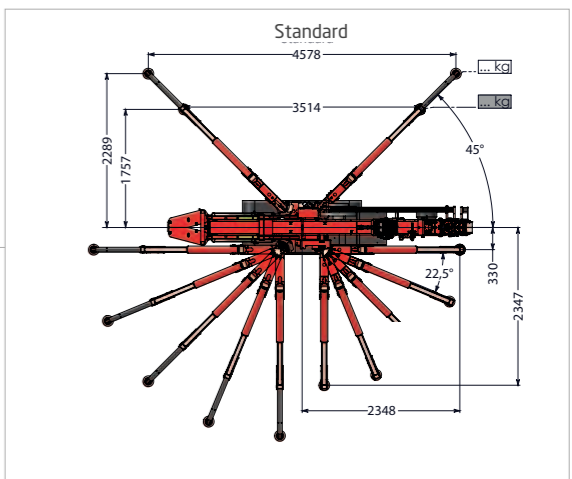
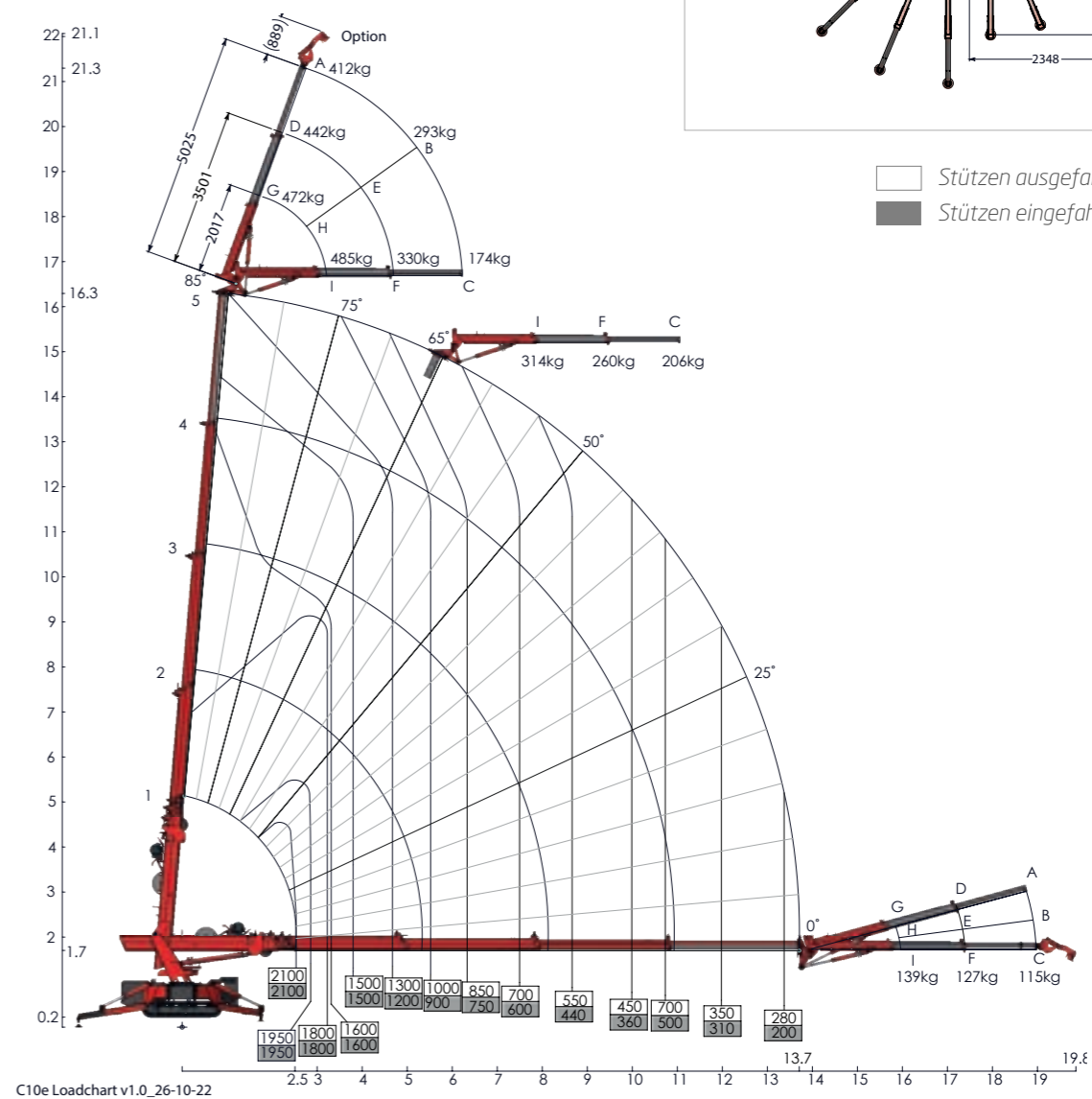

□ Stützen ausgefahren
■ Stützen eingefahren